



www.doosan-iv.com

7 Series Forklifts

Pneumatic Diesel 3.5 to 5.5 ton Series

EPA Tier-4 / Euro Stage 3B



Lifting Your Dreams

MAIN SPECIFICATION

CHARACTERISTICS					
1	Model			D35S-7	D40S-7
2	Capacity	at rated load center	kg	3,500	4,000
3	Load center	distance	mm	600	600
4	Power type	electric,diesel,gasoline,LP-gas		Diesel	Diesel
5	Operator type	Stand-on, Driver-seated		Driver-seated	Driver-seated
6	Tire type	C=cushion, P=pneumatic, E=solid		P	P
7	Wheels(x=driven)	number, front/rear		x 2/2	x 2/2
DIMENSIONS					
8	Lift with STD two-stage mast	maximum fork height	mm	3,000	3,000
9		free lift	mm	160	160
10	Fork carriage	ISO class		III	III
11	Forks	thickness x width x length	mm	50x150x1,050	50x150x1,050
12	Tilt of mast	forward/backward	deg	8/10	8/10
13	Overall dimensions	length without forks	mm	3,100	3,151
14		width	mm	1,372	1,451
15		mast lowered height	mm	2,225	2,230
16		mast extended height	mm	4,265	4,270
17		to top overhead guard	mm	2,225	2,230
18	Minimum outside turning radius		mm	2,770	2,820
19	Load moment constant		mm	561	561
PERFORMANCE					
20	Speed	travel, loaded/unloaded	km/h	24.5/26.2	24.7/26.4
21		lift, loaded/unloaded	mm/s	570/610	560/610
22		lowering, loaded/unloaded	mm/s	480/450	480/450
23	Drawbar pull	at 1.6 km/h, loaded	kg	3,578	3,522
24	Gradeability	at 1.6 km/h, loaded	%	41.5	36.9
WEIGHT					
25	Total weight	unloaded	kg	5,900	6,190
26	Axle load	with loaded, front/rear	kg	8,250/1,150	8,910/1,280
27		without loaded, front/rear	kg	2,640/3,260	2,695/3,495
CHASSIS					
28	Tires	number of front/rear		2/2	2/2
29		size, front single		8.25x15-14	300x15-18
30		dual(option)		7.50x16-12	7.50x16-12
31		size, rear		7.00x12-12	7.00x12-12
32	Wheel base		mm	2,000	2,000
33	Tread	front/rear	mm	1,138/1,115	1,153/1,115
34	Ground clearance	loaded, at the lowest point	mm	160	160
35		loaded, at center of wheelbase	mm	205	205
36	Brake	service		disc	disc
37		parking		ratchet	ratchet
DRIVE					
38	Battery	voltage/ampere-hour	V/AH	12/75	12/75
39	Engine	manufacturer/model		DI/D34	DI/D34
40		rated output (at rpm)	kW/rpm	55/2,450	55/2,450
41		max. torque	Nm/rpm	325/1,600	325/1,600
42		cycle/cylinders/displacement	cc	4/4/3,400	4/4/3,400
43	Transmission	type		powershift	powershift
44		No. speeds forward/reverse		2/2	2/2
45	Operating pressure	system/attachment	bar	190/140	190/140

D45S-7	D50C-7	D55C-7	D40SC-7	D45SC-7	D50SC-7	D55SC-7
4,500	5,000	5,500	4,000	4,500	5,000	5,500
600	600	600	500	500	500	500
Diesel	Diesel	Diesel	Diesel	Diesel	Diesel	Diesel
Driver-seated	Driver-seated	Driver-seated	Driver-seated	Driver-seated	Driver-seated	Driver-seated
P	P	P	P	P	P	P
x 2/2	x 2/2	x 2/2	x 2/2	x 2/2	x 2/2	x 2/2
3,000	3,050	3,050	3,000	3,000	3,000	3,050
160	170	170	160	160	160	170
IV	IV	IV	III	III	IV	IV
50x150x1,200	60x150x1,200	60x150x1,200	50x150x1,050	50x150x1,050	50x150x1,200	60x150x1,200
8/10	8/10	8/10	8/10	8/10	8/10	8/10
3,265	3,300	3,350	3,100	3,151	3,265	3,300
1,451	1,451	1,451	1,372	1,451	1,451	1,451
2,230	2,380	2,380	2,225	2,230	2,230	2,380
4,420	4,470	4,470	4,265	4,270	4,420	4,470
2,230	2,230	2,230	2,225	2,230	2,230	2,230
2,865	2,930	2,990	2,770	2,820	2,865	2,930
561	571	571	561	561	561	571
24.5/26.4	24.3/26.4	24.2/26.2	24.5/26.2	24.7/26.4	24.5/26.4	24.3/26.4
550/610	540/610	530/610	570/610	560/610	550/610	540/610
480/450	490/450	490/450	480/450	480/450	480/450	490/450
3,531	3,519	3,490	3,578	3,522	3,531	3,519
34.4	31.5	28.2	41.5	36.9	34.4	31.5
6,635	7,185	7,530	5,900	6,190	6,635	7,185
9,795/1,340	10,725/1,460	11,400/1,630	8,690/1,210	9,350/1,340	10,235/1,400	11,165/1,520
2,750/3,885	3,010/4,175	3,155/4,375	2,640/3,260	2,695/3,495	2,750/3,885	3,010/4,175
2/2	2/2	2/2	2/2	2/2	2/2	2/2
300x15-18	300x15-18	300x15-18	8.25x15-14	300x15-18	300x15-18	300x15-18
7.50x16-12	7.50x16-12	7.50x16-12	7.50x16-12	7.50x16-12	7.50x16-12	7.50x16-12
7.00x12-12	7.00x12-14	7.00x12-14	7.00x12-12	7.00x12-12	7.00x12-12	7.00x12-14
2,100	2,100	2,100	2,000	2,000	2,100	2,100
1,153/1,115	1,153/1,115	1,153/1,115	1,138/1,115	1,153/1,115	1,153/1,115	1,153/1,115
160	160	160	160	160	160	160
205	205	205	205	205	205	205
disc	disc	disc	disc	disc	disc	disc
ratchet	ratchet	ratchet	ratchet	ratchet	ratchet	ratchet
12/75	12/75	12/75	12/75	12/75	12/75	12/75
DI/D34	DI/D34	DI/D34	DI/D34	DI/D34	DI/D34	DI/D34
55/2,450	55/2,450	55/2,450	55/2,450	55/2,450	55/2,450	55/2,450
325/1,600	325/1,600	325/1,600	325/1,600	325/1,600	325/1,600	325/1,600
4/4/3,400	4/4/3,400	4/4/3,400	4/4/3,400	4/4/3,400	4/4/3,400	4/4/3,400
powershift	powershift	powershift	powershift	powershift	powershift	powershift
2/2	2/2	2/2	2/2	2/2	2/2	2/2
210/140	210/140	230/140	190/140	190/140	210/140	210/140

DIMENSIONAL DRAWING

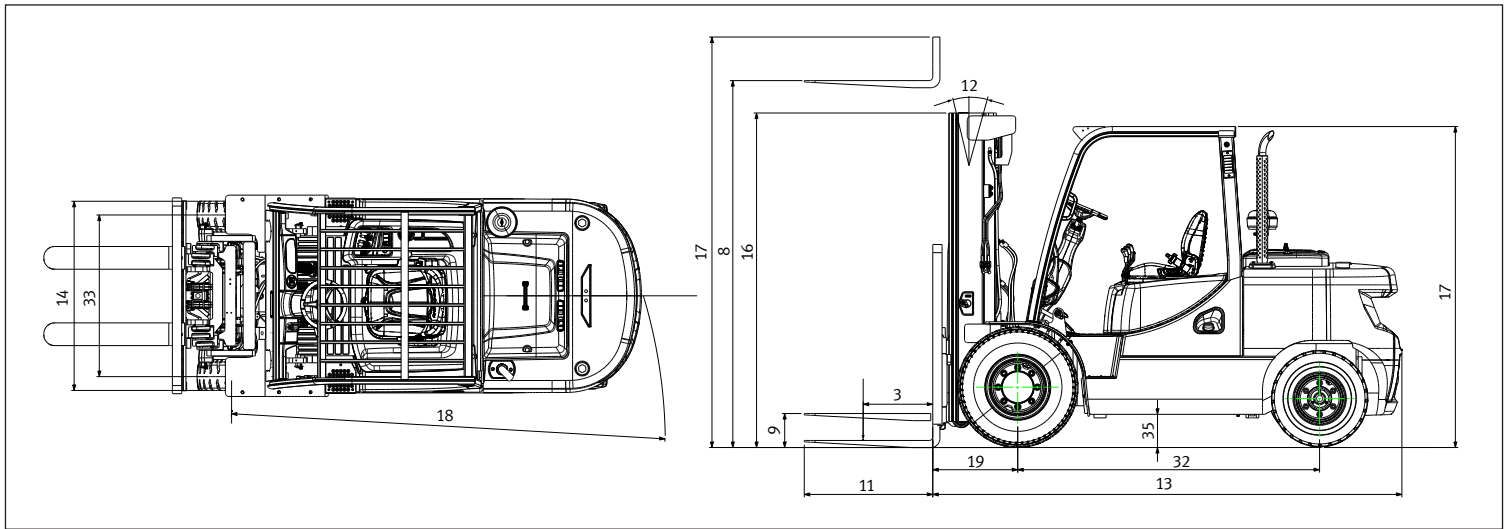

MAST SPECIFICATIONS and RATED CAPACITIES

D35S-7, D40SC-7

Mast type	Maximum Fork Height	Maximum Lowered Height	Fully Extended Height	Free Lift	Rated Load Capacities							
					D35S-5, D40SC-7							
					Tilt Angle				Load Capacities			
					Single Pneu.		Double Pneu		Single Pneu.		Double Pneu	
		With Load Backrest	With Load Backrest	FWD	BWD	FWD	BWD	LC 500mm	LC600mm	LC500mm	LC600mm	
	mm	mm	mm	mm	deg	deg	deg	deg	kg	kg	kg	kg
STD	3,000	2,225	4,265	160	8	10	8	10	4,000	3,655	4,000	3,655
	3,300	2,375	4,565	160	8	10	8	10	4,000	3,655	4,000	3,655
	3,650	2,550	4,915	160	8	10	8	10	4,000	3,655	4,000	3,655
	4,000	2,875	5,265	160	8	10	8	10	4,000	3,655	4,000	3,655
	4,250	3,000	5,515	160	8	10	8	10	4,000	3,655	4,000	3,655
	4,850	3,450	6,115	160	8	8	8	10	3,850	3,520	3,875	3,545
FF	3,000	2,205	4,250	1,005	8	10	8	10	4,000	3,660	4,000	3,660
FFT	4,000	2,090	5,265	890	8	8	8	8	3,975	3,645	4,000	3,670
	4,250	2,175	5,530	975	8	8	8	8	3,900	3,575	3,950	3,625
	4,700	2,325	5,980	1,125	8	8	8	8	3,775	3,465	3,800	3,485
	5,150	2,475	6,430	1,275	8	5	8	8	3,650	3,350	3,675	3,370
	5,600	2,625	6,880	1,425	8	3	8	8	3,525	3,235	3,550	3,255
	6,050	2,775	7,330	1,575	8	3	8	5	3,075	2,820	3,450	3,165

D40S-7, D45SC-7

Mast type	Maximum Fork Height	Maximum Lowered Height	Fully Extended Height	Free Lift	Rated Load Capacities							
					D40S-7, D45SC-7							
					Tilt Angle				Load Capacities			
					Single Pneu.		Double Pneu		Single Pneu.		Double Pneu	
		With Load Backrest	With Load Backrest	FWD	BWD	FWD	BWD	LC 500mm	LC600mm	LC500mm	LC600mm	
	mm	mm	mm	mm	deg	deg	deg	deg	kg	kg	kg	kg
STD	3,000	2,230	4,270	160	8	10	8	10	4,500	4,115	4,500	4,115
	3,300	2,380	4,570	160	8	10	8	10	4,500	4,115	4,500	4,115
	3,650	2,555	4,920	160	8	10	8	10	4,500	4,115	4,500	4,115
	4,000	2,880	5,270	160	8	10	8	10	4,500	4,115	4,500	4,115
	4,250	3,005	5,520	160	8	10	8	10	4,500	4,115	4,500	4,115
	4,850	3,455	6,120	160	8	8	8	10	4,400	4,025	4,425	4,045
FF	3,000	2,210	4,255	1,010	8	10	8	10	4,500	4,115	4,500	4,115
FFT	4,000	2,090	5,270	890	8	8	8	8	4,500	4,125	4,500	4,125
	4,250	2,180	5,535	980	8	8	8	8	4,475	4,105	4,500	4,125
	4,700	2,330	5,985	1,130	8	8	8	8	4,325	3,965	4,350	3,990
	5,150	2,480	6,435	1,280	8	5	8	5	4,175	3,830	4,225	3,875
	5,600	2,630	6,885	1,430	8	3	8	3	4,050	3,715	4,075	3,740
	6,050	2,780	7,335	1,580	8	3	8	3	3,800	3,485	3,750	3,440

Note : Mast Specifications & Rated Capacities are based on standard chassis with pneumatic tire and without side shifter.

D45S-7, D50SC-7

Mast type	Maximum Fork Height	Maximum Lowered Height	Fully Extended Height	Free Lift	Rated Load Capacities							
					D45S-7, D50SC-7							
			With Load Backrest	With Load Backrest	Tilt Angle				Load Capacities			
					Single Pneu.		Double Pneu		Single Pneu.		Double Pneu	
					FWD	BWD	FWD	BWD	LC 500mm	LC600mm	LC500mm	LC600mm
mm	mm	mm	mm	deg	deg	deg	deg	kg	kg	kg	kg	
STD	3,000	2,230	4,420	160	8	10	8	10	5,000	4,570	5,000	4,570
	3,300	2,380	4,720	160	8	10	8	10	5,000	4,570	5,000	4,570
	3,650	2,555	5,070	160	8	10	8	10	5,000	4,570	5,000	4,570
	4,000	2,880	5,420	160	8	10	8	10	5,000	4,570	5,000	4,570
	4,250	3,005	5,670	160	8	10	8	10	5,000	4,570	5,000	4,570
	4,850	3,455	6,270	160	8	5	8	10	4,900	4,480	4,700	4,25
FF	3,000	2,210	4,400	860	8	10	8	10	5,000	4,575	5,000	4,575
FFT	4,000	2,090	5,415	740	8	8	8	8	5,000	4,585	5,000	4,585
	4,250	2,180	5,680	830	8	8	8	8	4,975	4,565	5,000	4,585
	4,700	2,330	6,130	980	8	8	8	8	4,800	4,400	4,850	4,450
	5,150	2,480	6,580	1,130	8	3	8	8	4,650	4,265	4,525	4,150
	5,600	2,630	7,030	1,280	8	3	8	5	4,500	4,125	4,125	3,785
	6,050	2,780	7,480	1,430	8	3	8	3	3,575	3,280	3,575	3,280

D50C-7, D55SC-7

Mast type	Maximum Fork Height	Maximum Lowered Height	Fully Extended Height	Free Lift	Rated Load Capacities							
					D50C-7, D55SC-7							
			With Load Backrest	With Load Backrest	Tilt Angle				Load Capacities			
					Single Pneu.		Double Pneu		Single Pneu.		Double Pneu	
					FWD	BWD	FWD	BWD	LC 500mm	LC600mm	LC500mm	LC600mm
mm	mm	mm	mm	deg	deg	deg	deg	kg	kg	kg	kg	
STD	2,750	2,230	4,170	170	8	10	8	10	5,500	5,030	5,500	5,030
	3,050	2,380	4,470	170	8	10	8	10	5,500	5,030	5,500	5,030
	3,400	2,555	4,820	170	8	10	8	10	5,500	5,030	5,500	5,030
	3,750	2,880	5,170	170	8	10	8	10	5,500	5,030	5,500	5,030
	4,000	3,005	5,420	170	8	10	8	10	5,500	5,030	5,500	5,030
	4,600	3,455	6,020	170	8	8	8	10	5,500	5,030	5,125	4,690
FF	2,875	2,210	4,275	870	8	10	8	10	5,500	5,035	5,500	5,035
FFT	3,875	2,090	5,290	750	8	8	8	8	5,500	5,050	5,500	5,050
	4,125	2,180	5,555	840	8	8	8	8	5,500	5,050	5,500	5,050
	4,575	2,330	6,005	990	8	8	8	8	5,375	4,935	5,425	4,980
	5,025	2,480	6,455	1,140	8	5	8	8	5,200	4,775	4,600	4,220
	5,475	2,630	6,905	1,290	8	3	8	5	4,650	4,270	4,200	3,855
	5,925	2,780	7,355	1,440	8	3	8	5	3,625	3,330	3,275	3,005

D55C-7

Mast type	Maximum Fork Height	Maximum Lowered Height	Fully Extended Height	Free Lift	Rated Load Capacities							
					D55C-7							
			With Load Backrest	With Load Backrest	Tilt Angle				Load Capacities			
					Single Pneu.		Double Pneu		Single Pneu.		Double Pneu	
					FWD	BWD	FWD	BWD	LC 500mm	LC500mm	LC500mm	LC500mm
mm	mm	mm	mm	deg	deg	deg	deg	kg	kg	kg	kg	
STD	2,750	2,230	4,170	170	8	10	8	10	5,500	5,500	5,500	5,500
	3,050	2,380	4,470	170	8	10	8	10	5,500	5,500	5,500	5,500
	3,400	2,555	4,820	170	8	10	8	10	5,500	5,500	5,500	5,500
	3,750	2,880	5,170	170	8	10	8	10	5,500	5,500	5,500	5,500
	4,000	3,005	5,420	170	8	10	8	10	5,500	5,500	5,500	5,500
	4,600	3,455	6,020	170	8	8	8	10	5,400	5,400	4,900	4,900
FF	2,875	2,210	4,275	870	8	10	8	10	5,500	5,500	5,500	5,500
FFT	3,875	2,090	5,290	750	8	8	8	8	5,500	5,500	5,500	5,500
	4,125	2,180	5,555	840	8	8	8	8	5,500	5,500	5,500	5,500
	4,575	2,330	6,005	990	8	8	8	8	5,500	5,500	5,500	5,500
	5,025	2,480	6,455	1,140	8	5	8	8	5,150	5,150	4,425	4,425
	5,475	2,630	6,905	1,290	8	3	8	5	4,500	4,500	4,050	4,050
	5,925	2,780	7,355	1,440	8	3	8	5	3,500	3,500	3,125	3,125

Note : Mast Specifications & Rated Capacities are based on standard chassis with pneumatic tire and without side shifter.



Doosan Industrial Vehicle Europe nv
Europark-Noord 36A
9100 Sint-Niklaas, Belgium
Tel : +32 3 760 09 87
Fax : +32 3 760 09 89
Website : www.doosan-iv.eu

2015 MAR

AUTHORIZED DEALER